

R&S®EM100

Digital Compact Receiver

Compact radiomonitoring from 9 kHz to 7.5 GHz



R&S®EM100

Digital Compact Receiver

At a glance

The R&S®EM100 digital compact receiver has been specifically designed as a cost-efficient mobile radiomonitoring solution. The receiver's operation via remote control software and its monitoring functionality have been optimized for tasks requiring a handoff receiver in combination with a high-speed search receiver, for example. In addition, it can be used for a variety of other applications.

The R&S®EM100 digital compact receiver has an excellent feature set for monitoring transmissions, detecting interference, locating miniature transmitters or even functioning as a handoff receiver. In addition, it is extremely compact and consumes very little power. The R&S®EM100 is the optimum solution for systems with tight budgets, combining cost efficiency with technical capabilities that yield the desired results. When combined with analysis software (such as R&S®CA100), it provides users with a compact receiving and analysis system covering a wide frequency range from 9 kHz to 7.5 GHz.

The receiver can be operated with diverse antennas such as broadband omnidirectional antennas and directional antennas.

Though compact, the entry-level R&S®EM100 receiver offers a wide range of functions otherwise available only in equipment in higher price segments. Its favorable price/performance ratio makes it an indispensable instrument for all types of radiomonitoring tasks where space-saving integration and cost efficiency are crucial.

Thanks to its compact size and low weight, the R&S®EM100 is ideal for use in vehicles, aircraft (as a payload) and unmanned aerial vehicles (UAV).

Key facts

- Fast panorama scan with up to 1.8 GHz/s across the entire frequency range from 9 kHz to 7.5 GHz
- 10 MHz IF spectrum and demodulation with bandwidths from 150 Hz to 500 kHz
- Automatic bearing information of emissions with direction finding algorithms (20 MHz to 6 GHz)
- Spectrum and spectrogram (waterfall) display via the R&S®EM100-Control software
- Synchronization of receiver frequency and time using the R&S®ESMD-IGT internal GPS module
- High-accuracy timestamps in I/Q baseband data stream for use in TDOA systems
- LAN interface for remote control and data output
- Low power consumption for long-term operation from an autonomous power source
- Space-saving system integration due to ½ 19" width and one height unit
- Classification and analysis of signals up to 500 kHz bandwidth (analog and digital modulation) using the R&S®CA100 software
- Low weight (approx. 2.5 kg)



Front panel with no control elements; remote control via LAN interface.

R&S®EM100XT Digital Compact Receiver At a glance

The weatherproof R&S®EM100XT digital compact receiver has inherited all the functionality of the R&S®EM100. In addition, the R&S®EM100XT with IP 67 protection class enables cost-efficient outdoor fixed or mobile radiomonitoring. The receiver is operated via the same user-friendly remote control software (R&S®EM100-Control) that is used for the R&S®EM100.



R&S®EM100XT with mounting bracket.

The robust receiver's weatherproof enclosure makes it suitable for short and long-term outdoor deployment. It is well protected against rain and dust. With the R&S®EM100XT-IG option, a GPS module can easily be installed in the device to transform the receiver into a TDOA sensor node. The R&S®EM100XT-DF option can also be added for direction finding tasks. When both options are installed (plus a GPS antenna and DF antenna), the R&S®EM100XT becomes a hybrid solution for effectively and accurately determining the direction from which an emitter is transmitting.

The mounting brackets (R&S®EM100XT-BR) were specially designed for conveniently fixing the device to any pole or wall structure. The tilted top-plate functions as a sun shade. Well-fitted side handles (R&S®EM100XT-HD) are available for easy transportation.

Key facts

- Same functionality as R&S®EM100
- IP67 weatherproof housing
- Integrated heating device for operating temperatures as low as -25°C
- Integrated GPS module for enhanced frequency and timing accuracy
- LAN interface for remote control and data output
- Data buffering to internal SD card for time-shifted data output via LAN interface



R&S®EM100XT with handles.

R&S®EM100

Digital Compact Receiver

Applications

Interference detection and location in professional radio networks

- Reliable detection of radio interference caused, for example, by defective electronic equipment
- Fast and effective elimination of interference sources, e.g. at airports

▷ [page 6](#)

Monitoring of user-specific radio services

- Monitoring of a large number of radio services with different scan modes

▷ [page 7](#)

Reception and evaluation of emergency signals

- Demodulation of emergency signals to retrieve their contents
- Continuous monitoring of an emergency channel during operation as a handoff receiver

▷ [page 8](#)

Handoff receiver in a networked system

- Parallel demodulation of multiple narrowband signals and simultaneous broadband spectrum scanning

▷ [page 9](#)

Signal analysis and classification

- Signal overview and analysis, even of signal contents
- Automatic detection and classification of signals of unknown modulation

▷ [page 10](#)

Tracking of miniature transmitters

- Detection of bugs, e.g. in conference rooms
- Suppression of strong, external transmitters in the differential spectrum; accentuation of weak, local transmitters
 - Operation of two R&S®EM100 receivers in differential mode; control via the R&S®ARGUS software
 - Use of the R&S®HE600 wideband antenna for signal detection within and outside the conference room; subsequent comparison via R&S®ARGUS

▷ [page 11](#)

R&S®EM100

Digital Compact Receiver

Benefits and key features

High receiver sensitivity, high signal resolution

- State-of-the-art digital signal processing for high receiver sensitivity and detection of extremely weak signals without any loss in processing speed
- Significantly superior receiver sensitivity and signal resolution (compared with conventional analog broadband receivers)

Retrieval of information through demodulation and operation as handoff receiver

- Analog-modulated signals demodulated directly in the receiver; contents audible using headphones
- Digitally modulated signals converted to the baseband by means of I/Q demodulation and exported via LAN
- Offline analysis of digital signals, e.g. with the R&S®CA100

Monitoring receiver and signal analysis in a compact system

- Online LAN transfer from an R&S®EM100 to a PC and to the R&S®CA100 analysis software, for example, to operate an efficient small system for signal reception and analysis
- Recording of captured data using R&S®CA100; provision of data for documentation, replay or subsequent additional evaluation

Efficient operation via remote control

- Remote control of all receiver functions via LAN interface (SCPI command set in line with IEEE 488.2)
- LAN interface for providing the maximum measured data rate during receiver operation; efficient remote operation in unattended monitoring stations (interface essential, especially for system integrators who need to incorporate the receiver into existing software environments)

Convenient R&S®EM100-Control remote control software

- Short learning curve due to straightforward menu structure and simple operation
- Parameterization of displayed signals (depending on task), optimum display on screen
- Remote control of receiver via PC, recording of measured data on hard disk, and replay of data on PC for analysis purposes
- Expansion of remote control software functionality through options and add-ons from the R&S®RAMON software suite

DF functionality with R&S®EM100-DF upgrade kit

The R&S®EM100 supports DF functionality when upgraded with the R&S®EM100-DF upgrade kit. Using the patented Rohde & Schwarz single-channel correlative interferometer DF method (above 173 MHz), it provides DF accuracy and immunity to reflections comparable to that of direction finders with two or more receive paths. In the frequency range below 173 MHz, the Watson-Watt direction finding method is used. This method offers high DF accuracy even for small DF antennas. In combination with the R&S®EM100-DF upgrade kit, the R&S®EM100 becomes an accurate, compact and cost effective DF solution.

The R&S®EM100 is combined with R&S®ADD107 and R&S®ADD207 compact DF antennas to provide users with a wide direction finding frequency range from 20 MHz to 6 GHz. Both the R&S®ADD107 and R&S®ADD207 compact DF antennas come with an integrated GPS system and an electronic compass that can be used to display DF results on a map. When used with the R&S®ADD17XZ3 vehicle adapter with magnetic mount or the R&S®ADD17XZ6 wooden tripod, the solution allows quick and easy setup of DF stations and mobile direction finders.

Compact design and low power consumption

- Compact size and low weight for effective integration in small systems
- Particularly when installed in vehicles: compact design and low power consumption enable simultaneous operation of multiple R&S®EM100, e.g. as handoff receivers

Future-ready investment

- Wide frequency range and outstanding performance
- Capable of receiving and processing signals of current and future radio services

Interference detection and location in professional radio networks

Its compact design and wide range of special functions make the R&S®EM100 an ideal choice for cost-effectively detecting all types of radio interference.

Reliable detection of radio interference caused, for example, by defective electronic equipment

To master these tasks, the receiver includes special functions such as selectable measurement time and continuous or periodic level output. Since these functions are also effective in the panorama scan spectrum, even non-periodic interferers can be easily detected. Such interferers are otherwise very difficult to detect due to their irregular appearance in a quickly changing spectrum.

Fast and effective elimination of interference sources, e.g. at airports

The simultaneous use of the R&S®CA100 analysis software allows efficient differentiation between wanted signals and possible interference signals. Fast differentiation is especially important in security-critical radio scenarios (e.g. aeronautical radio, ATC) as it prevents high failure costs for the service provider. The combination of a fast panorama scan to acquire an overview of the situation with subsequent scanning and analysis in fixed-frequency mode based on I/Q data is particularly well suited to such applications.

In the panorama scan mode, the frequency range of interest is scanned in steps of max. 10 MHz, and an FFT of suitable width is calculated for each step. The step width for the fast panorama scan can be selected to match the channel spacing used by a wide variety of radio services. The panorama scan provides high scan rates at narrow resolution bandwidths for high sensitivity.

Interference in radiocommunications, e.g. at airports, not only impedes operation – it may even pose a threat to life.



Monitoring of user-specific radio services

The frequency scan mode is especially designed for monitoring radio services with fixed channel spacing.

Monitoring of a large number of radio services with different scan modes

In the frequency scan mode, a user-defined frequency range is scanned using fixed channel spacing. The receiver steps through the frequency range of interest and checks every channel for occupancy. If a signal is detected with a level exceeding the predefined threshold, the receiver dwells at the corresponding frequency for the set hold time, allowing for the signal to be demodulated and processed. In the case of analog modulation, the demodulated signal can be monitored via the headphones.

In the memory scan mode, predefined channels stored in memory locations are consecutively scanned and checked for occupancy. The R&S®EM100 offers 1024 user-definable memory locations. Receive parameters can be assigned separately to each memory location.

The memory scan mode is particularly useful for scanning individual frequencies that do not have fixed channel spacing or that use different demodulation modes and bandwidths. The memory scan mode offers the user a higher degree of freedom than the frequency scan mode.

Interference-free operation that ensures the viability of an organization's own radio networks is vital not only for government operators.



Reception and evaluation of emergency signals

Several different emergency calls can be received simultaneously by using multiple R&S®EM100 receivers in parallel.

Demodulation of emergency signals to retrieve their contents

Continuous scanning of predefined emergency bands is the only way to ensure that an emergency call is received immediately and the required action can be initiated as soon as possible.

Continuous monitoring of an emergency channel during operation as a handoff receiver

By operating multiple R&S®EM100 receivers in parallel, it is possible to continuously audio-monitor a current emergency call while simultaneously scanning the entire emergency band. (The R&S®EM100-Control software supports any number of receivers.)

After an emergency call has been received, it is passed on to one of the receivers for processing of the information. At the same time, the use of additional receivers allows independent, parallel scanning for other emergency calls that might occur concurrently.

When a person in distress has been located by demodulating the emergency signal and processing its contents, the position information is immediately forwarded to the rescue team.

Simultaneous reception of multiple emergency channels

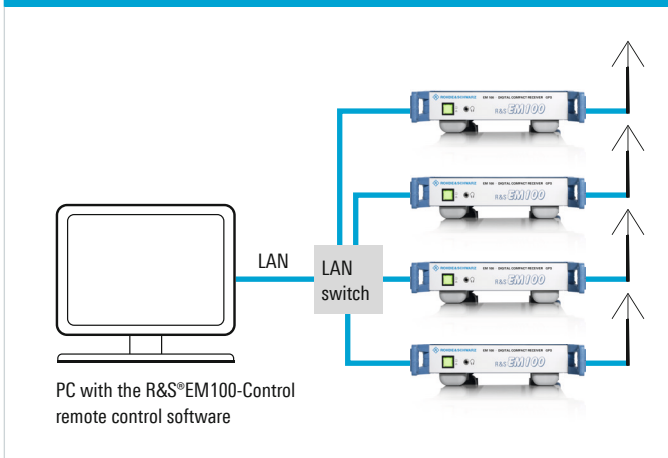

Handoff receiver in a networked system

Parallel demodulation of multiple narrowband signals and simultaneous broadband spectrum scanning

Multiple R&S®EM100 are combined with one or more fast and powerful search receivers (e.g. the R&S®EB500) and operated as a networked system. The R&S®EM100 demodulates narrowband signals and produces audio or I/Q data streams, while the R&S®EB500 quickly searches for other signals in the air with an extremely high level of sensitivity. A separate R&S®EM100 is required for each narrowband signal that is to be processed in parallel.

The handover of a narrowband signal from the R&S®EB500 to an R&S®EM100 is carried out from the user workstation using the R&S®RAMON system software. The major advantage of this system configuration is that the fast signal search across a wide frequency scenario and the narrowband production of multiple audio or I/Q data streams take place simultaneously. This allows the user to achieve optimum monitoring results in a minimum of time.

Networked system: Multiple R&S®EM100 can be operated together with one or more R&S®EB500 receivers.



Specifications in brief of the R&S®EB500

Frequency range	
Base unit	20 MHz to 3.6 GHz
HF option	9 kHz to 32 MHz
SHF option	3.6 GHz to 6 GHz
Linearity, third-order intercept, in-band	
9 kHz to 32 MHz	typ. 35 dBm (low distortion mode)
20 MHz to 650 MHz	typ. 19 dBm (low distortion mode)
650 MHz to 6 GHz	typ. 14 dBm (low distortion mode)
Noise figure	
400 kHz to 32 MHz	typ. 12 dB (normal mode)
20 MHz to 3.6 GHz	typ. 10 dB (normal mode)
3.6 GHz to 6 GHz	typ. 15 dB
IF bandwidth	
Spectral path	1 kHz to 20 MHz
Demodulation path	100 Hz to 5 MHz
Data interface	1 Gbit LAN (Ethernet 1000BASE-T)

Signal analysis and classification

Signals with analog or digital modulation up to 500 kHz bandwidth are analyzed by using the R&S®EM100 in conjunction with the R&S®CA100 software (additional PC needed).

Signal overview and analysis, even of signal contents

The R&S®CA100 analysis software provides a signal overview for the frequency range of interest using a fast spectral or waterfall display. Detection of known signals (with demodulation and decoding for content analysis) is supported along with fast monitoring and search analysis of unknown signals using an automatic classification system (with modulation mode detection or detection of transmission system or transmission codes).

Automatic detection and classification of signals of unknown modulation

The user defines the frequency range in which signals are to be automatically searched and classified using the R&S®CA100 software. Signals that are detected are automatically processed using the R&S®CA100 algorithm for modulation mode and transmission system classification. This search is performed by the R&S®EM100 by combining the panorama scan and the fixed frequency mode (FFM).

Together, the R&S®EM100 and R&S®CA100 analyze signals down to the bit level.

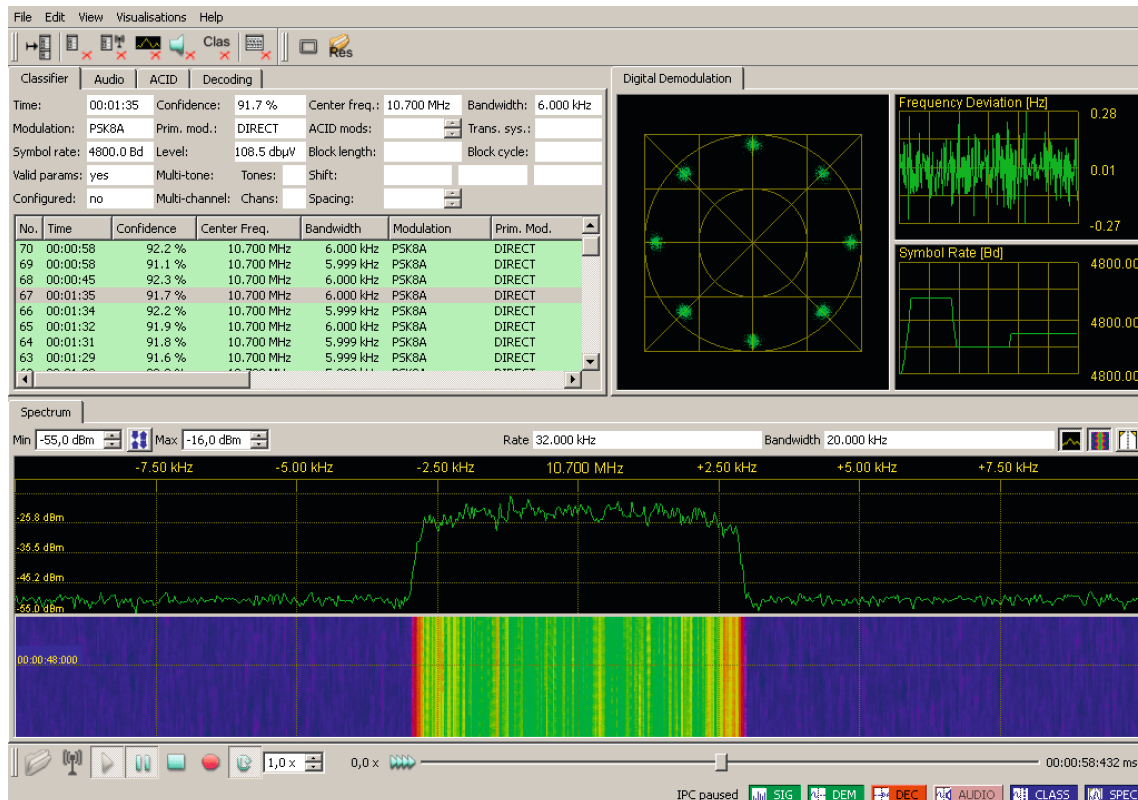

Tracking of miniature transmitters

Differential measurements make it possible to detect current spectral differences with respect to a reference spectrum such as may be caused by an active miniature transmitter (bug), for example.

Detection of bugs, e.g. in conference rooms

By combining two differential measurement modules, each comprising an R&S®EM100 receiver and an R&S®HE600 antenna, as well as the R&S®ARGUS system software, it is possible to detect differences between the signal spectrum of interest and a reference spectrum.

Suppression of strong, external transmitters in the differential spectrum; accentuation of weak, local transmitters

The scan spectrum received in a conference room is compared with a reference spectrum from another room through subtraction. This comparison is performed by the R&S®ARGUS software and yields a differential spectrum, i.e. the differences between the two spectra. This method considerably simplifies analysis by decreasing the amount of spectral information to analyze.

A powerful transmitter such as an FM radio station will be received with a similar level by the two receivers and will therefore be suppressed in the differential spectrum. However, a bug installed in the conference room will have a significantly higher level in the scan spectrum than in the reference spectrum. The differential spectrum will highlight this signal so that the bug can be found even more quickly.

System configuration for differential measurements with receivers, antennas and system software

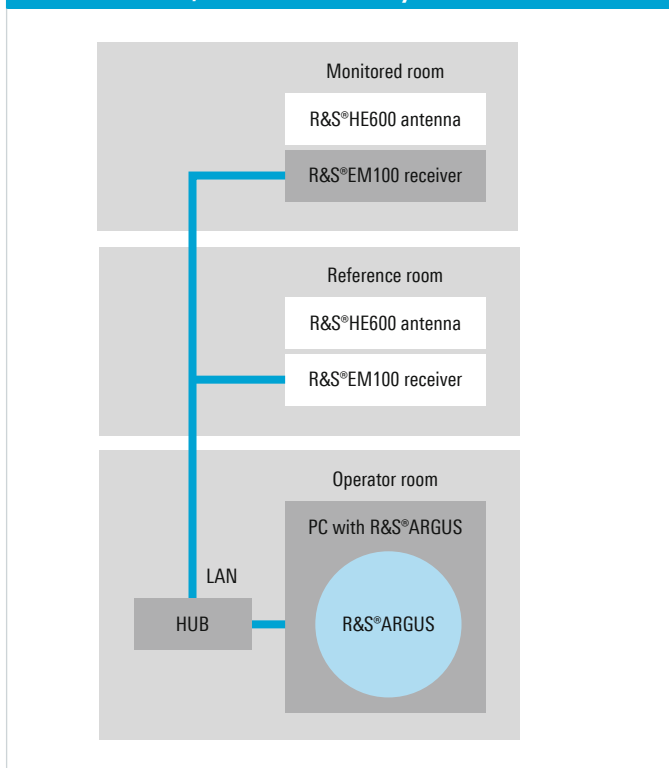

Display of differences in signal levels using the differential spectrum.



R&S®HE600 active omnidirectional receiving antenna

The R&S®HE600 is a versatile vertical polarization antenna. This broadband active omnidirectional receiving antenna offers excellent sensitivity over an extremely wide frequency range from 20 MHz to 8 GHz in a small form factor.

Two subrange antennas covering the entire monitoring range

To cover the entire frequency range, the R&S®HE600 consists of an active dipole and a passive antenna – the active dipole operating in the frequency range from 20 MHz to 1.1 GHz and the passive antenna with low-noise preamplifier for the frequency range from 1.1 GHz to 8 GHz. Both are combined to a single RF output with an integrated diplexer. This antenna is powered through the coax cable connected to its RF output by means of a supply unit, i.e. the R&S®IN600 bias unit.

Designed as a compact, shock-proof and weather-resistant radom, the R&S®HE600 is ideal for stationary or mobile installations and operates in versatile environmental conditions.

R&S®HE600 active omnidirectional receiving antenna and R&S®IN600 bias unit.



Specifications in brief	
Frequency range	20 MHz to 8 GHz
Nominal impedance	50 Ω
General data of the R&S®HE600 active omnidirectional receiving antenna	
Power supply	15 V to 28 V DC, typ. 24 V DC, max. 180 mA (via R&S®IN600 bias unit)
RF connector	N female
Weight	approx. 2 kg (4.41 lb)
Dimensions (Ø × H)	approx. 135 mm × 550 mm (5.31 in × 21.65 in)
General data of the R&S®IN600 bias unit	
Power supply	100 V to 240 V AC, 10 V to 32 V DC
Weight	approx. 3 kg (6.61 lb)
Dimensions (W × H × D)	approx. 400 mm × 250 mm × 65 mm (15.75 in × 9.84 in × 2.56 in)

Convenient R&S®EM100-Control remote control software

The R&S®EM100-Control remote control software enables convenient and efficient operation of the receiver from a PC workstation. The R&S®EM100-Control software, which is supplied free of charge with the R&S®EM100, is part of the R&S®RAMON software family. The software offers a straightforward menu structure and intuitive operation so that training requirements for operating personnel are minimal.

The complete functionality provided by the R&S®EM100 digital compact receiver can be controlled using the R&S®EM100-Control software. The graphical user interface allows operation of the receiver with easy-to-read online signal display as well as signal recording and replay. Optional R&S®RAMON software packages are available to significantly expand the range of functions, e.g. handover functions to and from additional receivers or direction finders, tasks and reporting as well as database functions. R&S®RAMON software components can be used to implement customer-specific radiomonitoring systems – from single, standalone systems to nationwide networked systems.

Major functional features of R&S®RAMON

Fast and easy to use

The main functions can be accessed using shortcuts.

The graphical display of results includes:

- IF spectrum with waterfall diagram
- RF panorama spectrum with waterfall diagram

The user can adapt the colors of the display and the size and arrangement of the windows as required for a specific task or area of application. Easy-to-use measurement functions are available within the diagrams.

Display, storage and replay of spectra and waterfall data

R&S®EM100-Control enables the recording and replay of RF and IF signal spectra. In addition, digital audio data and I/Q baseband data (digital IF) of up to 500 kHz bandwidth can be stored, e.g. for subsequent analysis of digitally modulated signals.

Buffering of frequency scan data in a ring buffer

Recording in the ring buffer can be stopped by a mouse click. The stored signals are then available in replay mode for analysis.

Frequency list for marking signals

With a mouse click, radio channels can be marked, saved in a list and graphically placed over the spectrum. The frequency list is available for storage and subsequent analysis.

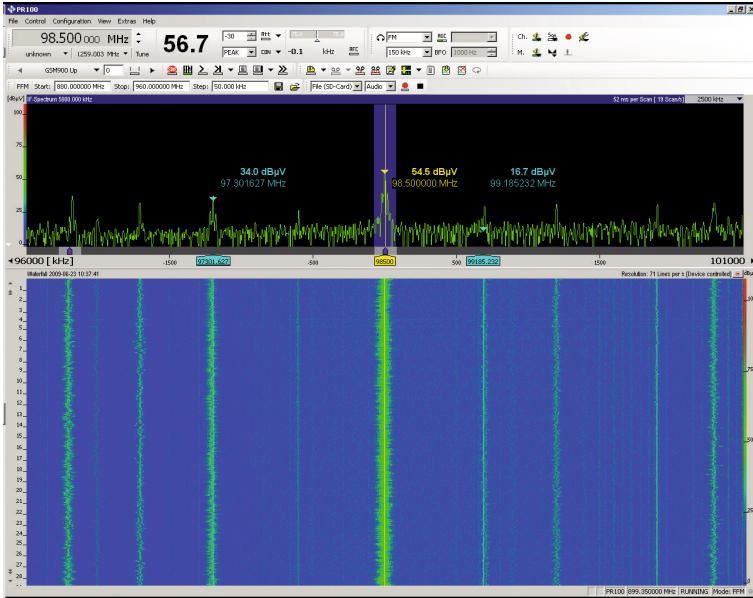

Display of IF spectrum and use of marker function.

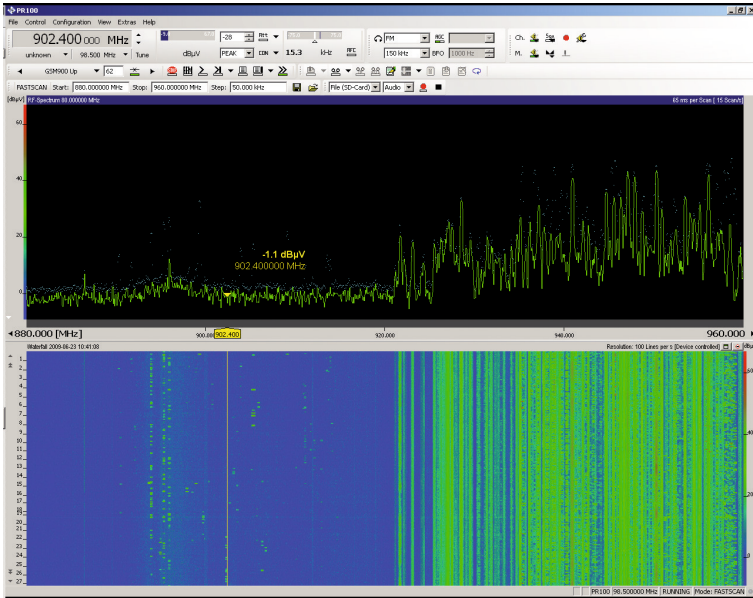

Wideband panorama scan with max. hold function and waterfall diagram.

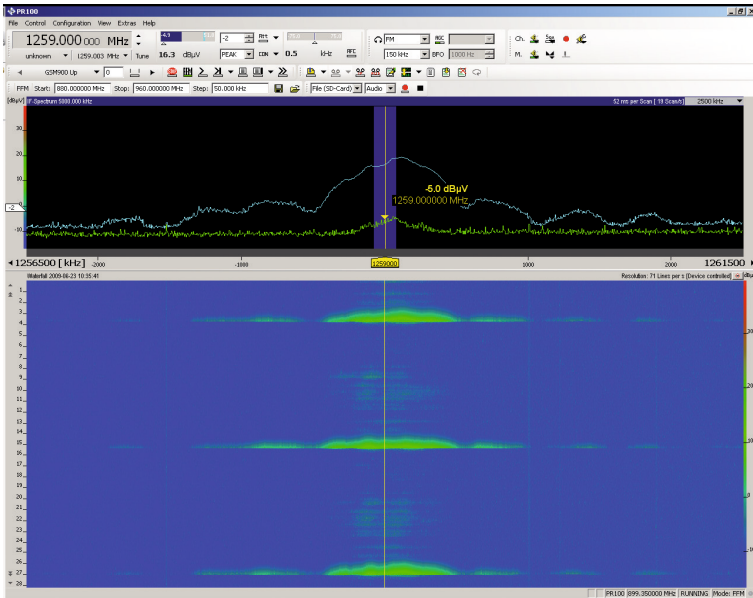

IF spectrum and waterfall diagram of a radar signal from the Munich Airport.

Operating principle

Frontend

Starting from the antenna socket, the frequency in the signal path is limited to 8 GHz for the hardware and 7.5 GHz for the software. Signal processing then takes place in three paths for three different frequency ranges.

Signals from 9 kHz to 30 MHz are routed via a preamplifier directly to the A/D converter. Signals from 20 MHz to 3.5 GHz are routed to the IF section through the preselection and a preamplifier, or through an attenuator in the case of high signal levels. Both the preselection and the attenuator effectively protect the IF section against overloading. This is particularly important in this frequency range where the maximum signal sum levels occur. Signals from 3.5 GHz to 8 GHz are routed to the IF section through a preamplifier.

The three-stage IF section processes the signals from 20 MHz to 8 GHz for the subsequent A/D converter. To provide optimum instrument performance, only signals up to 7.5 GHz are processed in the subsequent stages. The uncontrolled 21.4 MHz IF can also be tapped ahead of the A/D converter via a BNC socket on the R&S®EM100 for further external processing.

Digital signal processing

After A/D conversion of the signal, the signal path is split up:

- In the first path, the IF spectrum is calculated using a digital downconverter (DDC), a digital bandpass filter and the FFT block. The bandwidth of the bandpass filter can be selected between 1 kHz and 10 MHz. Before the IF spectrum is output via the LAN interface, results are postprocessed using the average, min. hold or max. hold function as selected by the user.
- In the second path, which also includes a DDC and a bandpass filter, the signal is processed for level measurement or demodulation. To process the different signals with optimum signal-to-noise ratio, the receiver contains IF filters with demodulation bandwidths from 150 Hz to 500 kHz, which can be selected independently of the IF bandwidth.

Prior to the level measurement, the absolute value of the level is determined and weighted using the average, max. peak, RMS or sample function, as selected by the user. The measured level is then output via the LAN interface.

To demodulate analog signals, the complex baseband data passes through the baseband filter, then undergoes automatic gain control (AGC) or manual gain control (MGC), and is finally demodulated in the AM, FM, USB, LSB, ISB, pulse or CW demodulation stages. After the AGC/MGC stage, the complex baseband data (I/Q data) resulting from the digitized signals is directly output for further processing.

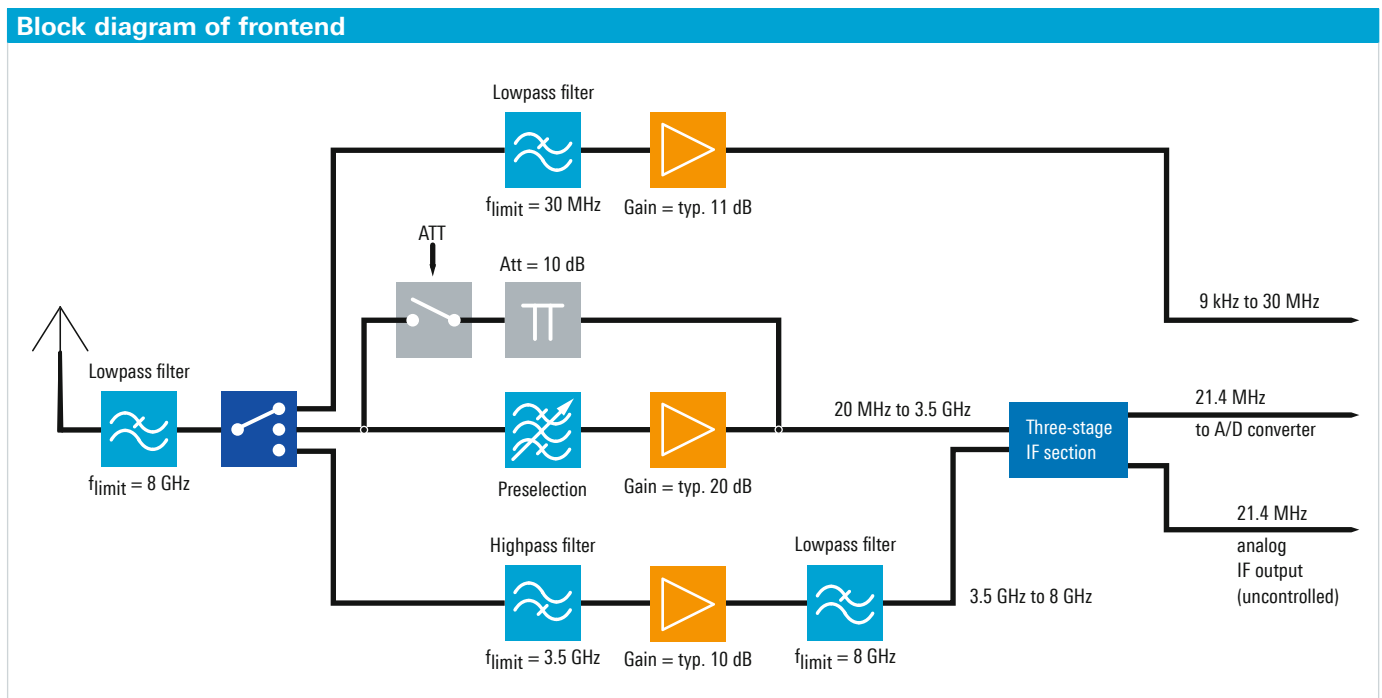

The results obtained are available as digital data and can be output via the LAN interface as required for the particular task. Digital audio data is reconverted to analog signals for output via the headphone socket.

High receiver sensitivity, high signal resolution

The R&S®EM100 features an IF bandwidth of up to 10 MHz. This allows even very short signal pulses to be captured since the receiver displays the wide bandwidth of 10 MHz in a single spectrum around the set center frequency without any scanning being required.

The widest IF bandwidth of 10 MHz yields the widest spectral display; the narrowest IF bandwidth of 1 kHz yields maximum sensitivity.

The receiver's IF spectrum is digitally calculated using a fast Fourier transform (FFT). The use of FFT computation at the IF level offers a major advantage: The receiver sensitivity and signal resolution are clearly superior to those of a conventional analog receiver at the same spectral display width.

IF spectrum

FFT calculation of the IF spectrum is performed in a number of steps. These are described below in simplified form for an IF bandwidth of 10 kHz ($BW_{IF\ spectrum} = 10\ kHz$), which yields high sensitivity.

Due to the finite edge steepness of the IF filter, the sampling rate f_s must be larger than the selected IF bandwidth $BW_{IF\ spectrum}$. Therefore, the quotient of the sampling rate and the IF bandwidth is > 1 and is a measure of the edge steepness of the IF filter. This relationship is expressed by the following two formulas:

$$\frac{f_s}{BW_{IF\ spectrum}} = const$$

or

$$f_s = BW_{IF\ spectrum} \times const$$

The value of the constant is dependent on the selected IF bandwidth, i.e. it may vary as a function of the IF bandwidth.

For an IF bandwidth of $BW_{IF\ spectrum} = 10\ kHz$, the constant is 1.28. Therefore, to display a 10 kHz IF spectrum, a sampling rate of $f_s = 12.8\ kHz$ is required.

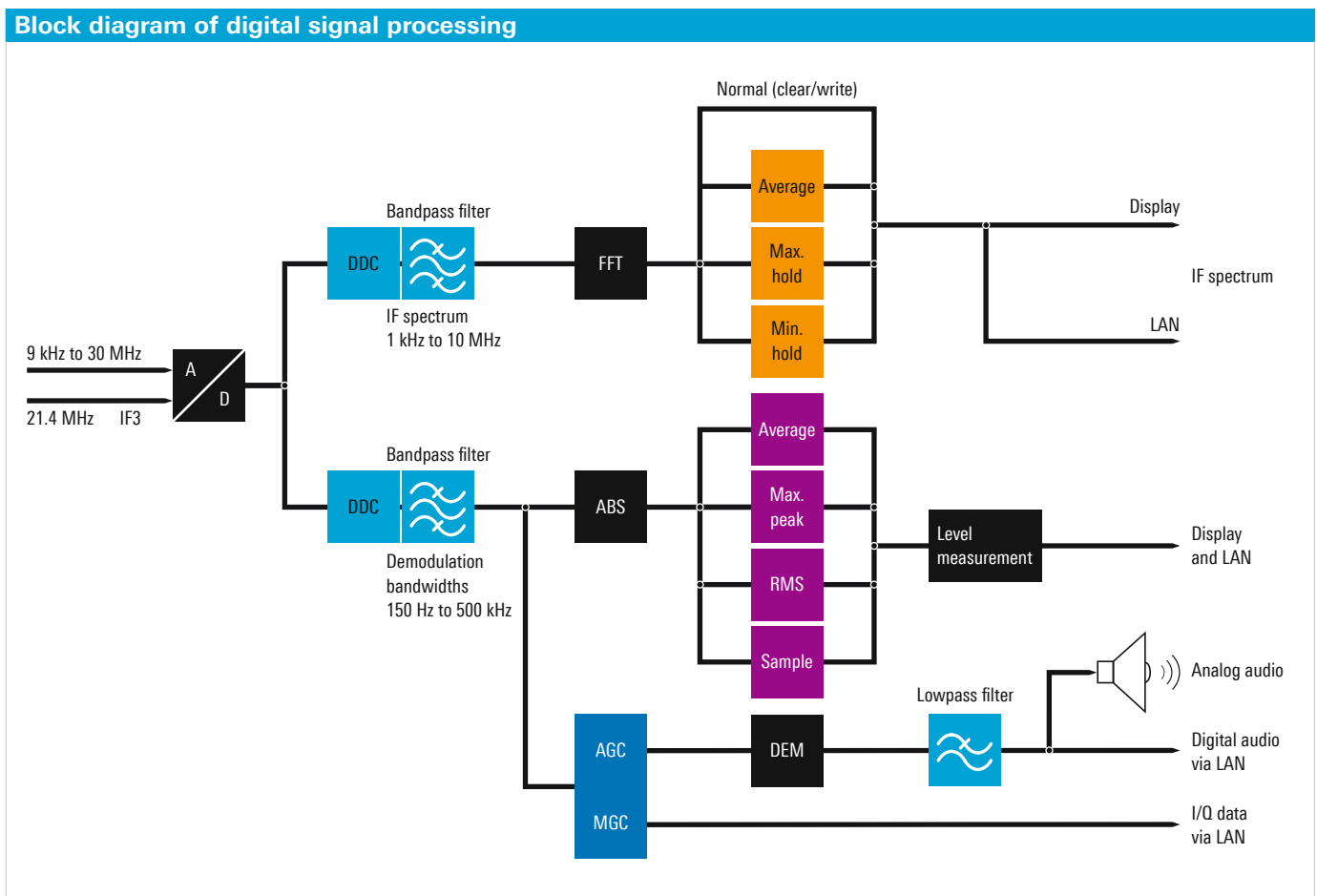

The R&S®EM100 uses an FFT length N of 2048 points to generate the IF spectrum. To calculate these points, the 12.8 kHz sampling band in the above example is divided into 2048 equidistant frequency slices, which are also referred to as bins (see figure "Signal processing for IF spectrum").

The bandwidth BW_{bin} of the frequency slices is as follows:

$$BW_{bin} = \frac{f_s}{2048} = \frac{12.8 \text{ kHz}}{2048} = 6.25 \text{ Hz}$$

This means that in the above example, only the calculated bandwidth of 6.25 Hz for each bin has to be taken into account as the noise bandwidth in the calculation of the displayed noise level (DNL) in accordance with the formula below (the effect of the window function (Blackman window) of the FFT is not considered here for simplicity's sake):

$$DNL = -174 \text{ dBm} + NF + 10 \times \log(BW_{bin}/\text{Hz})$$

The quantity NF represents the overall noise figure of the receiver.

The above example shows that, due to the use of the FFT, the actual resolution bandwidth (RBW) to be taken into account in the DNL calculation is clearly smaller (i.e. BW_{bin}) than would be expected for the wide display range of 10 kHz.

Another advantage of the high spectral resolution used in the FFT calculation is that signals located close together (e.g. f_1, f_2, f_3) can be captured and represented in the IF spectrum as discrete signals (see figure "Signal display in IF spectrum").

If, on an analog receiver, a resolution bandwidth equal to the set IF bandwidth was selected ($RBW = BW_{IF \text{ spectrum}}$), a sum signal f_{sum} would be displayed instead of the three discrete signals f_1, f_2 and f_3 .

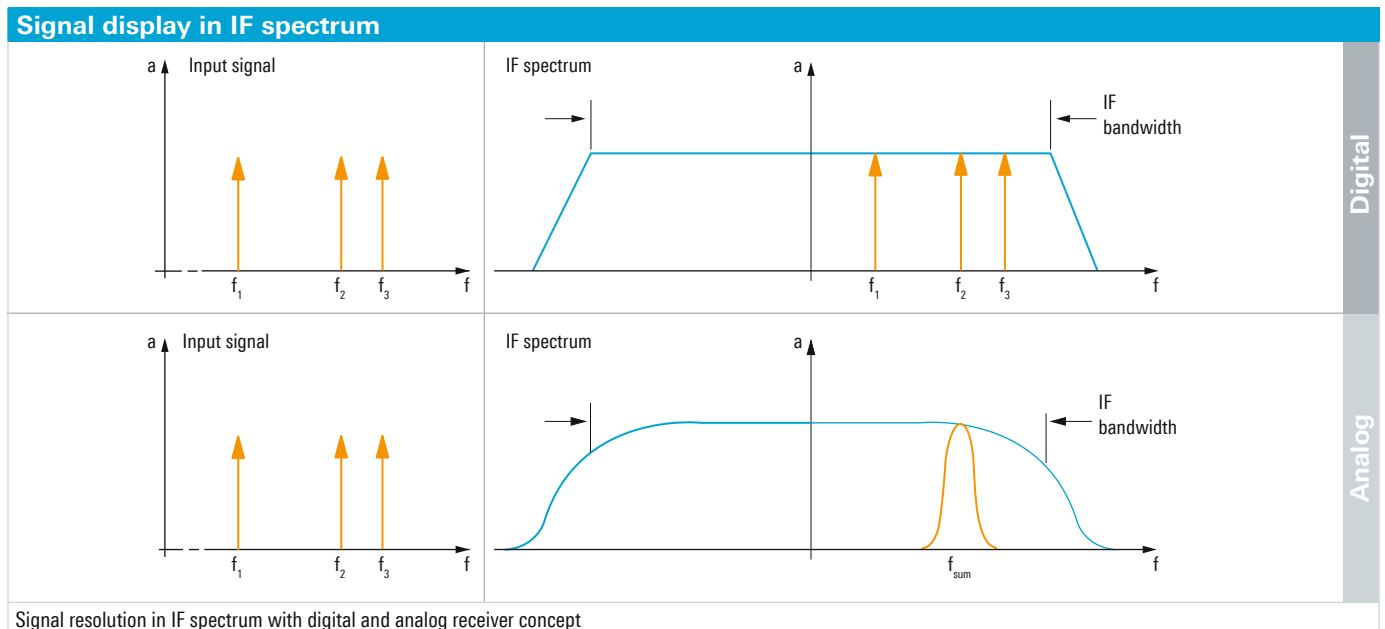
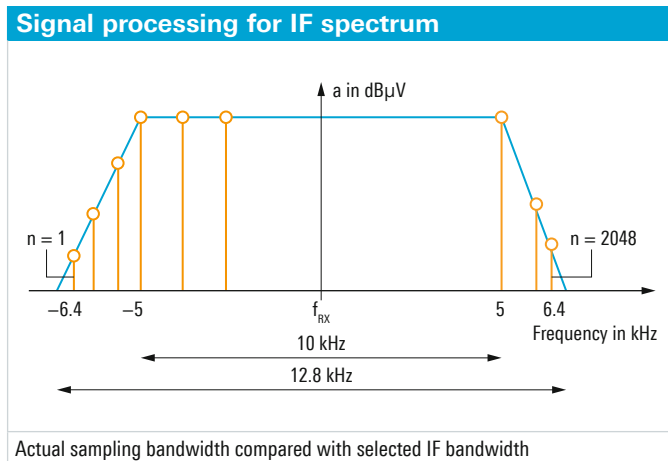

Panorama scan

The receiver's maximum FFT bandwidth of 10 MHz makes it possible to even perform extremely fast scans across a wide frequency range (panorama scan). For this purpose, frequency windows of max. 10 MHz width are linked in succession, so that the complete, predefined scan range is traversed (see figure "Signal processing in panorama scan mode"). As is done for the IF spectrum, an FFT is used to process the broad window with a finer resolution.

The width of the frequency window and the FFT length (number of FFT points) are variable and are selected by the receiver.

In the panorama scan mode, the user can select among 12 resolution bandwidths from 125 Hz to 100 kHz. The resolution bandwidth corresponds to the width of the frequency slices (bin width) mentioned under "IF spectrum". Based on the selected bin width and start and stop frequency, the R&S®EM100 automatically determines the required FFT length and the width of the frequency window for each scan step. The receiver selects these internal parameters so that the optimum scan speed is achieved for each resolution bandwidth (see figure "Resolution in panorama scan mode").

In the panorama scan mode, the resolution bandwidth of 100 kHz yields the maximum scan speed, while the resolution bandwidth of 125 Hz yields maximum sensitivity.

The resolution bandwidth (bin width) for the panorama scan (selectable between 125 Hz and 100 kHz) therefore corresponds to the resolution bandwidth (BW_{bin}) used in the DNL calculation for the IF spectrum (see DNL formula under "IF spectrum"), and can be used for calculating the DNL for the panorama scan. Moreover, the user selects the resolution bandwidth to obtain the desired frequency resolution (see figure "Bin width and channel spacing").

The above explanations show that the use of digital signal processing in a monitoring receiver offers decisive advantages. Extremely high sensitivity (due to very fine resolution) combined with a broad spectral overview and high scan speed significantly increase the probability of intercept in comparison with an analog receiver.

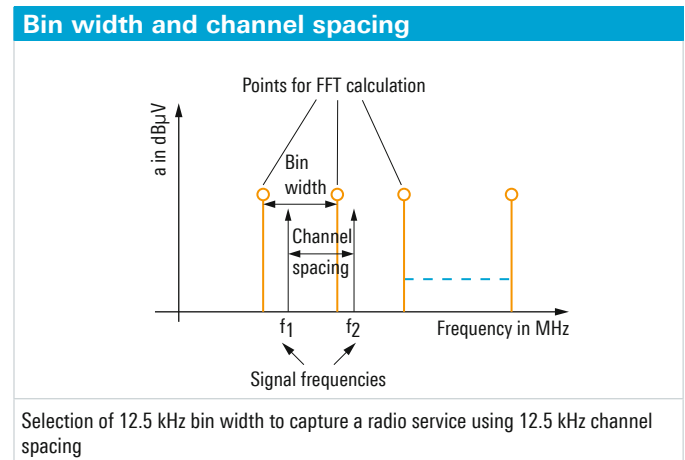
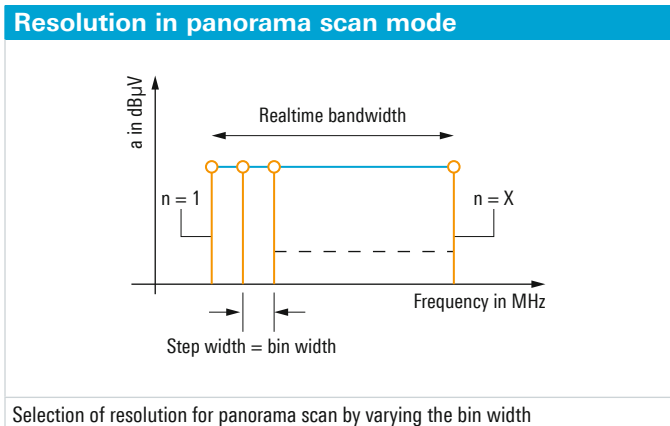
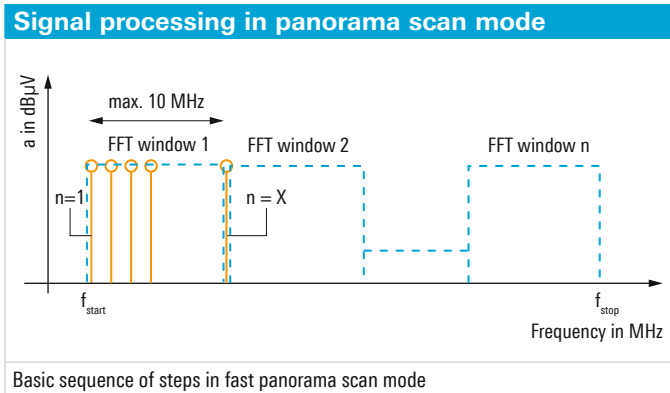

Specifications in brief

Specifications in brief		
RF data		
Frequency range	base unit	9 kHz to 3.5 GHz
	with R&S®EM100-FE option	9 kHz to 7.5 GHz
RF input		
Impedance		50 Ω
Preselection	9 kHz to 30 MHz	30 MHz lowpass filter
	20 MHz to 1.5 GHz	tuned bandpass filters
	1.5 GHz to 7.5 GHz	highpass/lowpass filter combination
IF data		
IF spectrum display range		1 kHz to 10 MHz, 1/2/5/10/20/50/100/200/500 kHz, 1/2/5/10 MHz
Display modes		normal (clear/write), average, max. hold, min. hold
IF demodulation bandwidths	15 filters (specified values indicate 3 dB bandwidth)	150/300/600 Hz, 1.5/2.4/6/9/15/30/50/120/150/250/300/500 kHz
Demodulation modes	all demodulation bandwidths	AM, FM, pulse, I/Q
	demodulation bandwidth ≤ 9 kHz	USB, CW
	demodulation bandwidth ≤ 9 kHz	LSB
	demodulation bandwidth ≤ 15 kHz	ISB
	demodulation bandwidth ≤ 9 kHz	CW
Scan modes		
Frequency scan (FScan)	start and stop frequency, step width	user-selectable
	scan speed	up to 150 channels/s
Memory scan (MScan)	memory locations	1024, user-programmable
	scan speed	up to 150 channels/s
Panorama scan (PScan)	start and stop frequency	user-selectable
	resolution bandwidths (bin widths)	125/250/500/625 Hz, 1.25/2.5/3.125/6.25/12.5/25/50/100 kHz
	scan speed (RBW = 100 kHz, measurement time = 500 μs, RF spectrum = normal, clear/write, display mode = RF spectrum)	up to 1.8 GHz/s
DF mode		
Frequency range		20 MHz to 6 GHz
DF method	20 MHz to 173 MHz	Watson-Watt
	173 MHz to 6 GHz	correlative interferometer

For data sheet, see PD 3607.0300.22 and www.rohde-schwarz.com

Ordering information

Designation	Type	Order No.
Digital Compact Receiver, frequency range from 9 kHz to 3.5 GHz, IF spectrum (max. 10 MHz), R&S®EM100-Control remote control software (basic package)	R&S®EM100 R&S®EM100XT	4070.4800.04 4500.9008.04
Frequency Range Extension, from 3.5 GHz to 7.5 GHz	R&S®EM100-FE R&S®EM100XT-FE	4070.4669.03 4070.4669.04
Documentation of Calibration Values	R&S®EM100-DCV R&S®EM100XT-DC	4071.9906.03 4071.9906.04
Software options		
Panorama Scan, RF scan, high-speed FFT scan across user-selectable scan range, selectable spectral resolution	R&S®EM100-PS R&S®EM100XT-PS	4071.9306.03 4071.9306.04
Field Strength Measurement, antenna factors are stored in the receiver for field strength calculation; the field strength is displayed directly in dBµV/m on the user interface of the remote control software	R&S®EM100-FS R&S®EM100XT-FS	4071.9506.03 4071.9506.04
Internal Recording, recording of measured data in receiver (RAM) or SD card, recording of audio data in WAV format (replay using Windows Media Player, for example), recording of I/Q data, spectra and spectrogram (waterfall) data, R&S®EM100-Control software for viewing measured data on customer PC	R&S®EM100-IR R&S®EM100XT-IR	4071.9358.03 4071.9358.04
Externally Triggered Measurements, an external sensor (not included) triggers a measurement in the R&S®EM100; the sensor is connected via the AUX interface	R&S®EM100-ETM R&S®EM100XT-ET	4071.9458.03 4071.9458.04
GPS Software Interface, for data stream processing of external GPS module (not included)	R&S®EM100-GPS R&S®EM100XT-GP	4071.9958.03 4071.9958.04
Direction Finder Upgrade Kit, adds accurate direction finding functionality to the R&S®EM100 receiver (DF antennas and cable set not included)	R&S®EM100-DF R&S®EM100XT-DF	4096.2805.03 4096.2805.04
Hardware options		
Internal GPS Module and External GPS Antenna ¹⁾ , for synchronization of reference frequency for high-precision timestamps and TDOA	R&S®EM100-IGT R&S®EM100XT-IG	4070.4952.02 4500.9820.02
Accessories		
Power Supply, operating temperature range from 0°C to +40°C	R&S®HA-Z201	1309.6100.00
Car Adapter, operating temperature range from 0°C to +40°C	R&S®HA-Z202	1309.6117.00
GPS Receiver, external GPS receiver for the R&S®EM100	R&S®HA-Z240	1309.6700.03
19" Rack Adapter (2 × R&S®EM100 side by side)	R&S®ZZA-T31	1109.4435.00
19" Rack Adapter (1 × R&S®EM100 + 1 × blind plate)	R&S®ZZA-T32	1109.4441.00
Handles for R&S®EM100XT	R&S®EM100XT-HD	4500.0140.00
Mounting Bracket for R&S®EM100XT	R&S®EM100XT-BR	4501.0210.00
Serial Cable, for connecting the receiver with a PC for receiver configuration (e.g. with unknown IP address)	R&S®EM100-AUX	4070.4230.02
Active Omnidirectional Receiving Antenna, 20 MHz to 8 GHz,	R&S®HE600	4094.9002.02
Bias Unit	R&S®IN600	
9 kHz to 8 GHz, for supply of one active antenna, 100 V to 240 V AC		4094.3004.11
9 kHz to 8 GHz, for supply of up to two active antennas, 100 V to 240 V AC		4094.3004.12
9 kHz to 8 GHz, for supply of one active antenna, 10 V to 32 V DC		4094.3004.21
9 kHz to 8 GHz, for supply of up to two active antennas, 10 V to 32 V DC		4094.3004.22
DF antennas and accessories		
Compact VHF/UHF DF Antenna	R&S®ADD107	4090.7005.02
Compact UHF/SHF DF Antenna	R&S®ADD207	4096.0002.02
Vehicle Adapter with Magnet Mount	R&S®ADD17XZ3	4090.8801.02
Wooden Tripod	R&S®ADD17XZ6	4090.8860.02
Cable Set with Converter	R&S®ADD17XZ5	4090.8660.02

¹⁾ The R&S®EM100-GPS GPS software interface option is included in the R&S®EM100-IGT option.

Service options

Extended Warranty, one year	R&S®WE1	Please contact your local Rohde&Schwarz sales office.
Extended Warranty, two years	R&S®WE2	
Extended Warranty, three years	R&S®WE3	
Extended Warranty, four years	R&S®WE4	
Extended Warranty with Calibration Coverage, one year	R&S®CW1	
Extended Warranty with Calibration Coverage, two years	R&S®CW2	
Extended Warranty with Calibration Coverage, three years	R&S®CW3	
Extended Warranty with Calibration Coverage, four years	R&S®CW4	

Service that adds value

- | Worldwide
- | Local and personalized
- | Customized and flexible
- | Uncompromising quality
- | Long-term dependability

About Rohde & Schwarz

The Rohde & Schwarz electronics group is a leading supplier of solutions in the fields of test and measurement, broadcast and media, secure communications, cyber-security, and radiomonitoring and radiolocation. Founded more than 80 years ago, this independent global company has an extensive sales network and is present in more than 70 countries. The company is headquartered in Munich, Germany.

Sustainable product design

- | Environmental compatibility and eco-footprint
- | Energy efficiency and low emissions
- | Longevity and optimized total cost of ownership

Certified Quality Management

ISO 9001

Certified Environmental Management

ISO 14001

Rohde & Schwarz GmbH & Co. KG

www.rohde-schwarz.com

Regional contact

- | Europe, Africa, Middle East | +49 89 4129 12345
customersupport@rohde-schwarz.com
- | North America | 1 888 TEST RSA (1 888 837 87 72)
customer.support@rsa.rohde-schwarz.com
- | Latin America | +1 410 910 79 88
customersupport.la@rohde-schwarz.com
- | Asia Pacific | +65 65 13 04 88
customersupport.asia@rohde-schwarz.com
- | China | +86 800 810 82 28 | +86 400 650 58 96
customersupport.china@rohde-schwarz.com

R&S® is a registered trademark of Rohde & Schwarz GmbH & Co. KG

Trade names are trademarks of the owners

PD 3607.0300.12 | Version 03.01 | April 2015 (sk)

R&S®EM100 Digital Compact Receiver

Data without tolerance limits is not binding | Subject to change

© 2014 - 2015 Rohde & Schwarz GmbH & Co. KG | 81671 Munich, Germany



3607030012