

TRUNCATED PYRAMIDAL ABSORBER APX

APX is a range of absorbers consisting of blocks of carbon-impregnated polyurethane foam in pyramid shape.

APX absorbers are suitable for microwave frequency to line anechoic or semi-anechoic chambers (for EMC measurements). This material makes it possible to obtain quiet zone in very wide frequency bands (80 MHz to 40 GHz) according to DO160 and MIL STD 461.

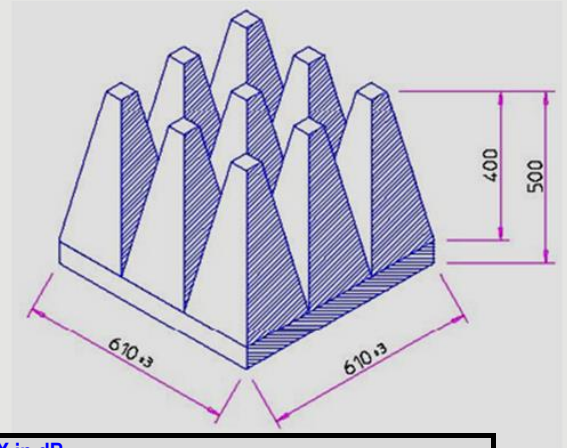

REFLECTIVITY PERFORMANCES

MINIMUM REFLECTIVITY OF APX in dB for incidence angles close to the normal								
Type	Height (mm)	80 MHz	100 MHz	200 MHz	300 MHz	500 MHz	1 GHz	8 GHz
APX 50	500	-6	-7	-20	-21	-27	-32	-37

MAIN CHARACTERISTICS

Matrix: polyurethane foam with 90% open cells.
Impregnating agents: carbon, binder, fire retardant.
Colours: black, white, blue, green, red (other colours upon request).
Paint: plastic coated for class clean rooms.

Maximum service temperatures: -65° C to 160° C.
Power handling: 0.2 W/cm² max CW.



COMPLIANCE TO STANDARDS & DIRECTIVES

Fire resistance: NRL 8093 (Test 1, 2, 3), ISO 11925-2, or DIN 4102 (class B2).

Our raw materials are compliant to **RoHS / REACH** and free of substances in the current list of Substances of Very High Concern (SVHC) published by the European Chemicals Agency (ECHA)

Both aqueous and plastic paint coating were developed to enable work in ISO 4 (ISO 14644-1 2015) clean room conditions.

DIMENSIONS

Type	A Total height (mm)	B Pyramid height (mm)	D Base height (mm)	E ± T* Base length (mm)		N Number of Pyramids per side	Weight (kg)
APX 50	500	400	100	610	±3	3	4.3



METHOD OF USE

APX absorbers type can be fixed to all flat surfaces by means of glue or of a Velcro fastening system or auto adhesive tape. Neoprene glue is applied with a brush or a pneumatic spray gun to both faces to be glued.

These data are the result of tests performed in our laboratory. They are considered to be the best of our knowledge. The use of the material and the specification of the performances are made under the whole responsibility of users who should ensure themselves that the material is suitable for their purposes.